

Quick Framer - Gambrel Roof

PLEASE READ ALL INSTRUCTIONS AND HELPFUL HINTS CAREFULLY BEFORE CONSTRUCTION

MADE IN U.S.A.

Tools needed: Hammer, Drill, Saw, Level, Square, Ladder

INSTRUCTIONS

1. Separate and stack all parts included in kit. STUD BRACKETS (12 pieces), "A" ANGLE BRACKETS (24 pieces) and "B" ANGLE BRACKETS (16 pieces) . Please refer to "A" or "B" stamped into each ANGLE BRACKET. Cut and mark all lumber to identify as stated in CUT LIST that corresponds to your structure size. Stack all lumber in separate areas.
2. In accordance with your size structure, nail BASE PLATE boards together overlapping ends to form structure base frame. (Picture #1) Use the pressure treated lumber for the bottom of the base frame to prevent rotting. Make sure base frame is square by measuring from corner to corner diagonally.
3. Using screws, attach STUD BRACKETS to outside of top base frame boards (Picture #2) using measurements listed on SIDE VIEW drawing of plans in accordance with your size structure. Measurements are to center of STUD BRACKETS.
4. (A-D) NOTE: In order to make sure each arch is built the same, stand short 2" x 4" scrap boards into RIDGE BOARD slots of each ANGLE BRACKET during assembly. (Picture #3)
(A.) Begin arch assembly by sliding two UPPER RAFTER boards into top ANGLE BRACKET "A" and secure with screws through SQUARE holes (for proper screw alignment) in bracket.
(B.) Attach two more "A" ANGLE BRACKETS to ends of each UPPER RAFTER board and secure with screws through square holes.
(C.) Slide LOWER RAFTER boards into ends of each "A" ANGLE BRACKET and secure with screws through square holes.
(D.) Attach ANGLE BRACKET "B" to ends of each LOWER RAFTER boards and secure with screws through square holes.
5. After ANGLE BRACKETS have been attached to one side of arch assembly, carefully turn arch over, leaving scrap boards in place in RIDGE BOARD slots.
6. Repeat steps # 4 (A) through (D) attaching ANGLE BRACKETS to other side of arch and secure using screws through the ROUND holes (for proper screw alignment) in ANGLE BRACKETS. Continue assembling the required number of arches according to your structure size.
7. Slide left and right STUDS into end of each ANGLE BRACKET "B" and secure using screws through ROUND holes. Carefully turn arch assembly over and secure ANGLE BRACKET "B" to STUDS using screws through SQUARE holes. Repeat this step on all arch assemblies.
8. Nail COLLAR TIE to LOWER RAFTER board of each arch assembly, making sure that the top corner of the COLLAR TIE is flush with the outside edge of LOWER RAFTER board. Be sure to attach the COLLAR TIES facing inside on the two end arches.
9. After all arch assemblies are complete, using two people carefully lift each arch onto the assembled base frame and secure to STUD BRACKETS using screws. Arches should be perpendicular to base frame (use a square). To hold the arches in a perpendicular position, use 1" x 4" temporary bracing inside of structure and leave in position until sheathing is in place, as shown in SIDE VIEW drawing. Leave nail heads slightly raised so they can be easily pulled out. The end arch assemblies should set flush with the base frame corners. Bend STUD BRACKETS around each corner of base frame and secure using screws.
10. After arch assemblies are set into place, remove scrap boards from "B" ANGLE BRACKET slots on one side of structure and place RIDGE BOARD into slots in "B" brackets. You may need to tap boards into place using a hammer. Repeat on opposite side of structure. Move up to lower ANGLE BRACKET "A" remove scrap boards and place RIDGE BOARD into slots in lower "A" brackets. Repeat on opposite side of structure. Remove scrap boards from top ANGLE BRACKET "A" and place RIDGE BOARD into slots in top "A" angle brackets. Make sure all arch assemblies are in correct positioning and adjust if needed. Secure all RIDGE BOARDS using screws through bottom holes in ANGLE BRACKETS. (For 10' x 22' structures, see #4 of Helpful Hints)
11. Install DOOR JAMBS as shown in FRONT VIEW drawings in accordance with your building size. Nail top of DOOR JAMBS to COLLAR TIE of end arch assembly. Screw STUD BRACKETS to bottom of each DOOR JAMB. Attaching to outside of top BASE PLATE.
12. Install two VERTICAL STUDS in back wall. (Same layout as Step 11) Nail top of VERTICAL STUDS to COLLAR TIE of end arch assembly. Screw STUD BRACKETS to bottom of each VERTICAL STUD. Attaching to outside of top BASE PLATE.
13. Your frame is now complete and ready to sheathe with materials of your choice. (See Helpful Hints)

HELPFUL HINTS (ALL SIZES)

1. Install wall sheathing horizontally on sides of 7'X8' building. Install wall sheathing vertically on ends of 7'X8' building. Install all wall sheathing vertically on larger size buildings. Install roof sheathing horizontally on all building sizes. Save the pieces of sheathing that you cut off and use them elsewhere (such as the other side of the roof). Use completed arch as pattern to trace cut lines on sheathing for ends of building.
2. Roofing material may be metal, corrugated fiberglass, rolled roofing or shingles.
3. Doors can be cut from plywood sheathing. Outline each half with 1X4 boards to make them rigid. Screw hinges to door jambs. On larger buildings, full sheets of plywood may be used to construct 8' doors.
4. On 10' x 22' structures, stagger ridge board seams as follows: Start at front end of structure and place 16' ridge board into slot in "B" brackets. (you may need to tap into place using a hammer) Move to back end of structure and place 6' ridge board into slot in remaining "B" angle brackets. Repeat on opposite side of structure. At front end of structure, move up to lower angle bracket "A" and place the 6' ridge board into slots in lower "A" angle brackets. Move to back end of structure and place 16' ridge board into slots in remaining lower "A" angle brackets. Repeat on opposite side. At front end of structure, move up to top "A" angle bracket and place the 16' ridge board into slots of top "A" angle brackets. Move to back end of structure and place the 6' ridge board into slots in remaining top "A" angle bracket. Make sure all arch assemblies are in correct positioning and adjust if needed. Secure all ridge boards using screws through bottom holes in angle brackets.
5. Optional 1X4's may be used as corner trim.
6. Sheathing may be installed above pressure treated base plates to prevent moisture damage.

G&T SALES, Inc.

415 Reservoir Road • Whitefish, MT 59937 • 1-406-253-5138 or 1-406-250-7054 • Fax 1-800-880-3178 • email: info@gtsales.us

U.S. Patent #5,524,397 Canadian Patent #2,227,540

FRONT VIEW (7'X8' BUILDING)

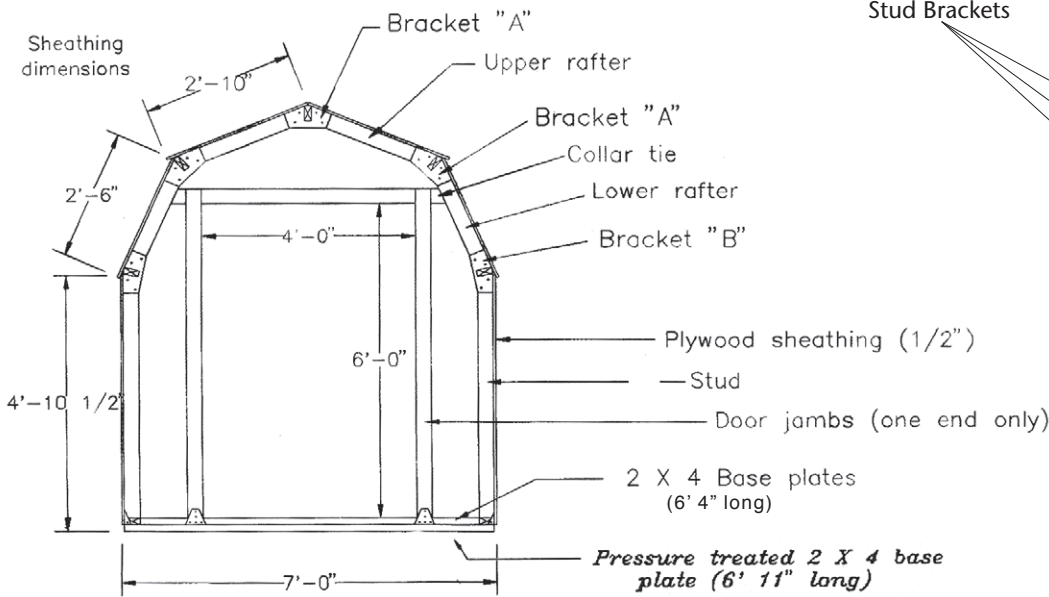

Stud Brackets



Picture #2

SIDE VIEW (7'X8' BUILDING)

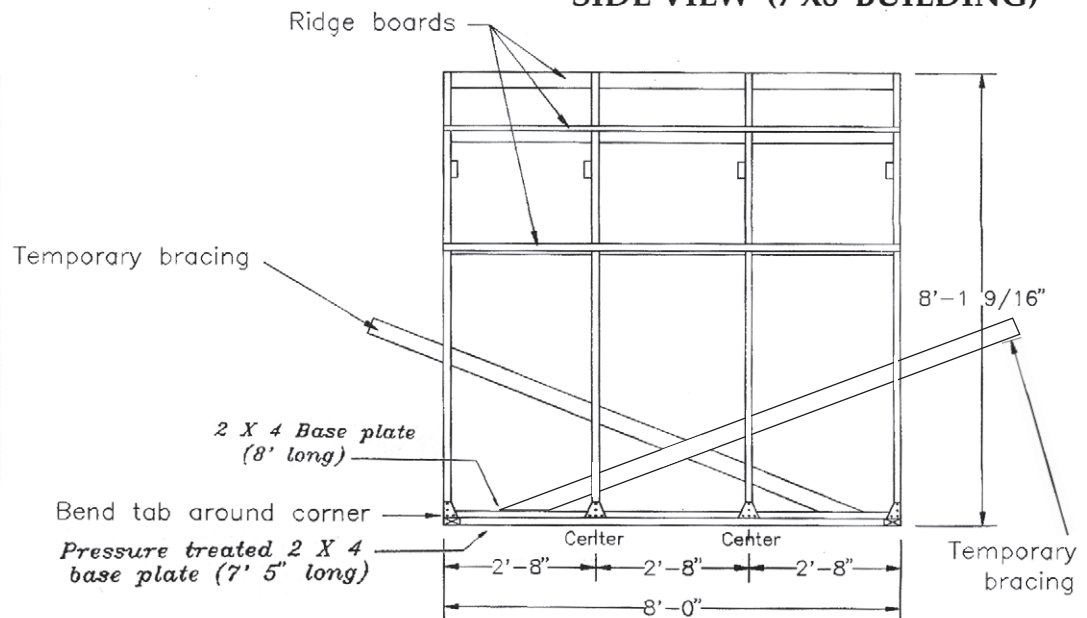

Picture #1

CUT LIST (7'X8' Building)

8 - 2X4 Studs cut to 4' 7-1/8"	(Cut from 4 -10')
8 - 2X4 Lower Rafters cut to 2' 1"	(Cut from 2 -10')
8 - 2X4 Upper rafters cut to 2' 4"	(Cut from 2 - 10')
4 - 2X4 Collar ties cut to 5' 6-1/4"	(Cut from 2 - 12')
2 - 2X4 Door jambs cut to 6' 3-1/2"	(Cut from 2 - 8')
2 - 2x4 Vertical studs cut to 6' 3-1/2"	(Cut from 2 - 8')
5 - 2X4 Ridge boards 8' long	(Use 5 - 8')
2 - 2X4 Base plates 8' long	(Use 2 - 8')
2 - 2x4 Base plates cut to 6' 4"	(Cut from 2 - 8')
4 - 1X4 Temp. bracing / door stiffener	(Use 4 - 8')
2 - 2X4 Pressure treated base plates cut to 7'5"	(Cut from 1 - 16')
2 - 2X4 Pressure treated base plates cut to 6' 11"	(Cut from 1 -16')



Quick Framer - Gambrel Roof

MATERIALS LIST

MATERIALS LIST (7'X8' Building)

GRADE #2 OR BETTER LUMBER IS RECOMMENDED

- 1 — Quick Framer Universal Framing Kit
- 13 — 8' 2X4's
- 8 — 10' 2X4's
- 2 — 12' 2X4's
- 2 — 16' Pressure Treated 2X4's
- 4 — 8' 1X4's
- 9 — 4X8 Sheets of sheathing material of your choice (plywood, waferwood, T-111 etc.)
- 86 square feet of roofing material of your choice (metal, fiberglass, rolled roofing, shingles, etc.)
- 2# — 3" Nails (16d)
- 2# — 1-1/4" Deck screws

MATERIALS LIST (8'X14' Building)

GRADE #2 OR BETTER LUMBER IS RECOMMENDED

- 2 — Quick Framer Universal Framing Kits
- 14 — 8' 2X4's
- 4 — 10' 2X4's
- 12 — 12' 2X4's
- 7 — 14' 2X4's
- 3 — 16' Pressure Treated 2x4's
- 6 — 8' 1X4's
- 16 — 4X8 Sheets of sheathing material of your choice (plywood, waferwood, T-111 etc.)
- 170 square feet of roofing material of your choice (metal, fiberglass, rolled roofing, shingles, etc.)
- 2# — 3" Nails (16d)
- 3# — 1-1/4" Deck screws

MATERIALS LIST (10'X22' Building)

GRADE #2 OR BETTER LUMBER IS RECOMMENDED

- 3 — Quick Framer Universal Framing Kits
- 49 — 8' 2X4's
- 18 — 10' 2X4's
- 3 — 12' 2X4's
- 7 — 16' 2X4's
- 4 — 16' Pressure Treated 2x4's
- 10 — 8' 1X4's
- 28 — 4X8 Sheets of sheathing material of your choice (plywood, waferwood, T-111 etc.)
- 330 square feet of roofing material of your choice (metal, fiberglass, rolled roofing, shingles, etc.)
- 4# — 3" Nails (16d)
- 5# — 1-1/4" Deck screws

G&T SALES, Inc.

415 Reservoir Road • Whitefish, MT 59937 • 1-406-253-5138 or 1-406-250-7054 • Fax 1-800-880-3178 • email: info@gtsales.us

MADE IN U.S.A. • Dealer Inquiries Invited

FRONT VIEW (8'X14' BUILDING)

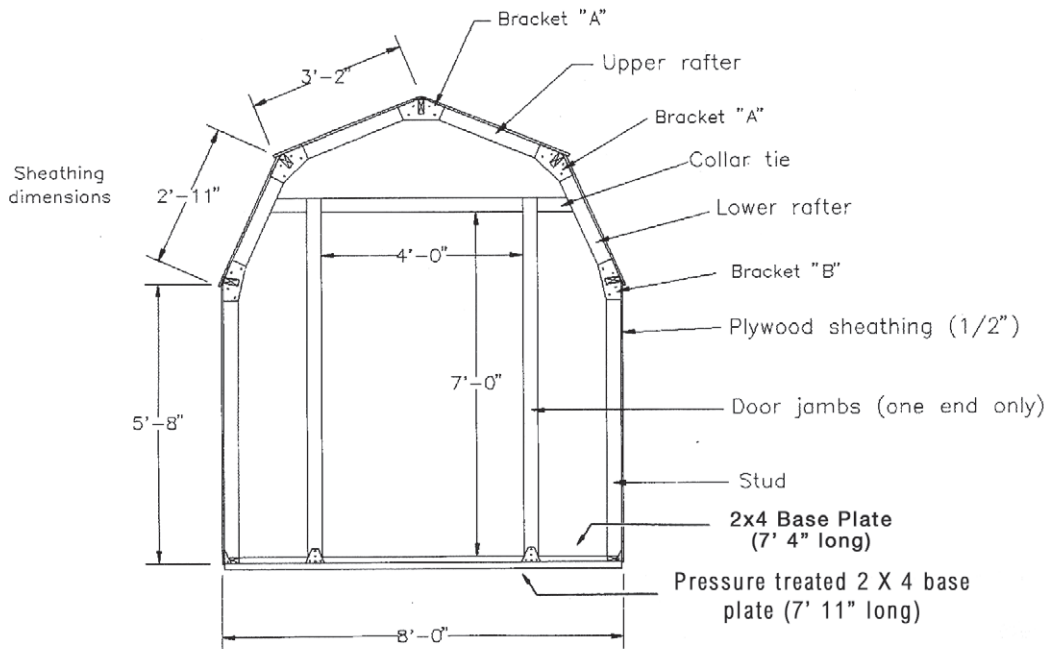

Picture #3

SIDE VIEW (8'X14' BUILDING)

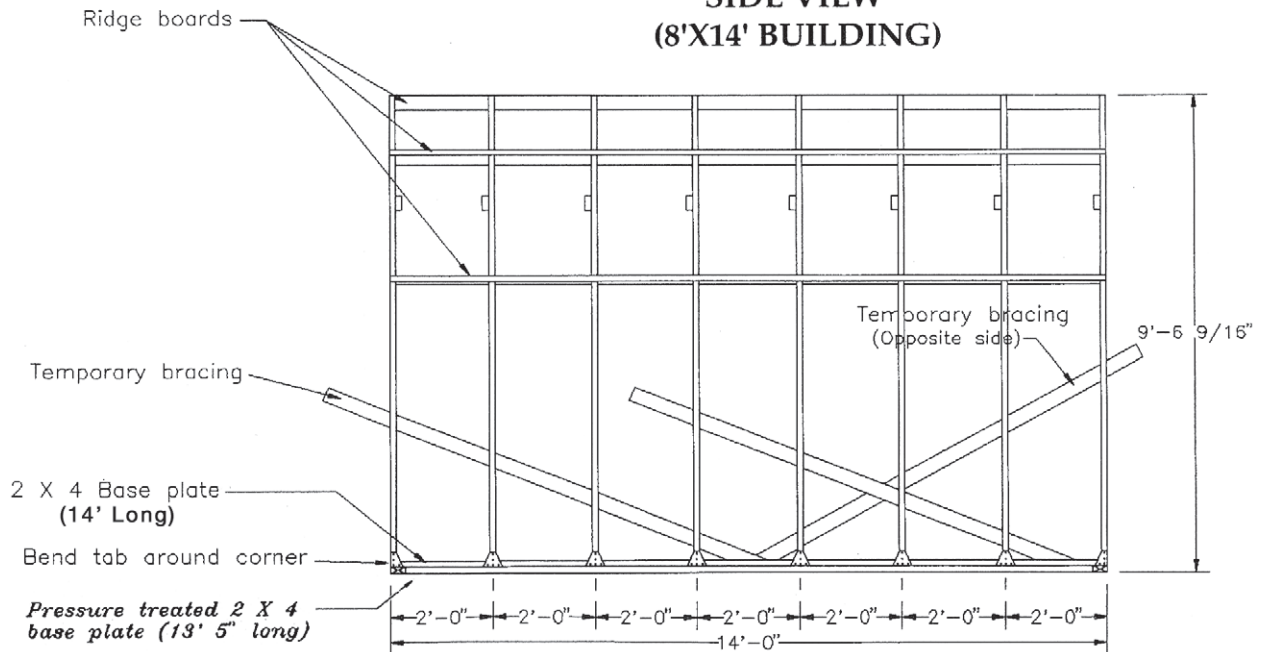

CUT LIST (8'X14' Building)

16 - 2X4 Studs cut to 5' 6"	(Cut from 8 - 12')
16 - 2X4 Upper rafters cut to 2' 8-1/4"	(Cut from 4 - 12')
16 - 2X4 Lower rafters cut to 2' 6"	(Cut from 4 - 10')
8 - 2X4 Collar ties cut to 6' 5-1/4"	(Cut from 8 - 8')
2 - 2X4 Door jambs cut to 7' 3-1/2"	(Cut from 2 - 8')
2 - 2x4 Vertical studs cut to 7' 3-1/2"	(Cut from 2 - 8')
2 - 2X4 Base plates 14' long	(Use 2 - 14')
2 - 2x4 Base plates cut to 7' 4"	(Cut from 2 - 8')
5 - 2X4 Ridge boards 14' long	(Use 5 - 14')
6 - 1X4 Temp. bracing/door stiffener	(Use 6 - 8')
2 - 2X4 Pressure treated base plates cut to 13' 5"	(Cut from 2 - 16')
2 - 2X4 Pressure treated base plates cut to 7' 11"	(Cut from 1 - 16')

FRONT VIEW (10'X22' BUILDING)

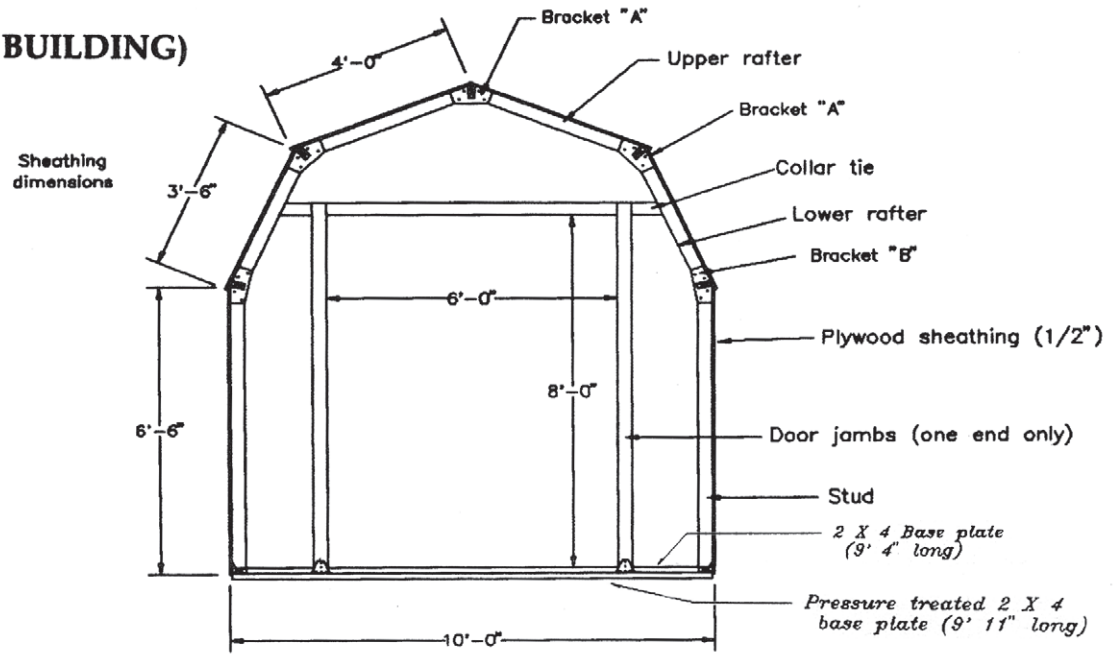

SIDE VIEW (10'X22' BUILDING)

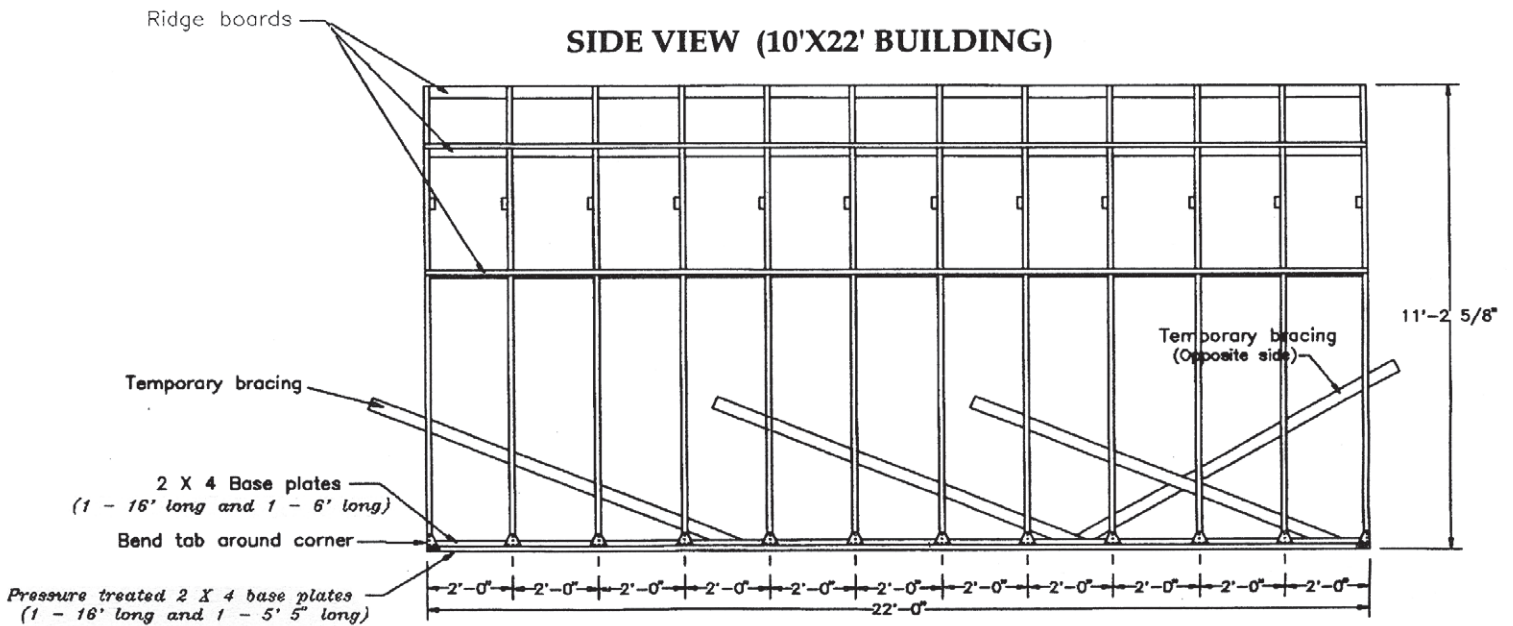

CUT LIST (10'X22' Building)

24 - 2X4 Studs cut to 6' 4"	(Cut from 24 - 8')
24 - 2X4 Upper rafters cut to 3' 6-1/8"	(Cut from 12 - 8')
24 - 2X4 Lower rafters cut to 3' 1"	(Cut from 12 - 8')
12 - 2X4 Collar ties cut to 8' 3-1/2"	(Cut from 12 - 10')
2 - 2x4 Door jambs cut to 8' 3-1/2"	(Cut from 2 - 10')
2 - 2x4 Vertical studs cut to 8' 3-1/2"	(Cut from 2 - 10')
2 - 2X4 Base plates 16' long	(Use 2 - 16')
2 - 2X4 Base plates cut to 6'	(Cut from 1 - 12')
2 - 2x4 Base Plates cut to 9' 4"	(Cut from 2 - 10')
5 - 2X4 Ridge boards 16' long	(Use 5 - 16')
5 - 2X4 Ridge boards 6' long	(Cut from 2 - 12' and 1 - 8')
10 - 1X4 Temp. bracing/ door stiffener	(Use 10 - 8')
2 - 2X4 Pressure treated base plates 16' long	(Use 2 - 16')
2 - 2X4 Pressure treated base plates cut to 9' 11"	(Cut from 2 - 16')
2 - 2X4 Pressure treated base plates cut to 5'5"	(Cut from above 16's)