

FRONT VIEW (10'X22' BUILDING)

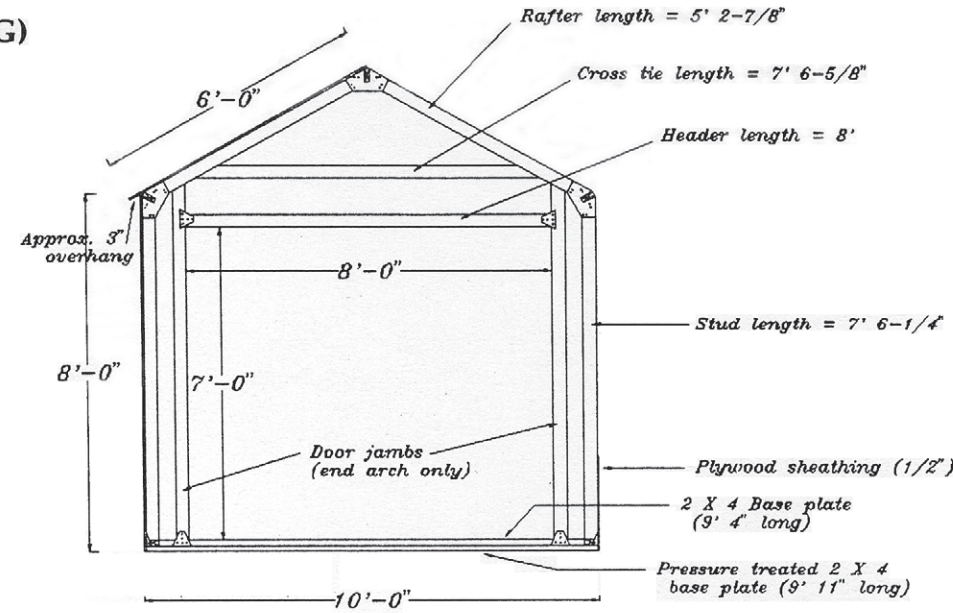

SIDE VIEW (10'X22' BUILDING)

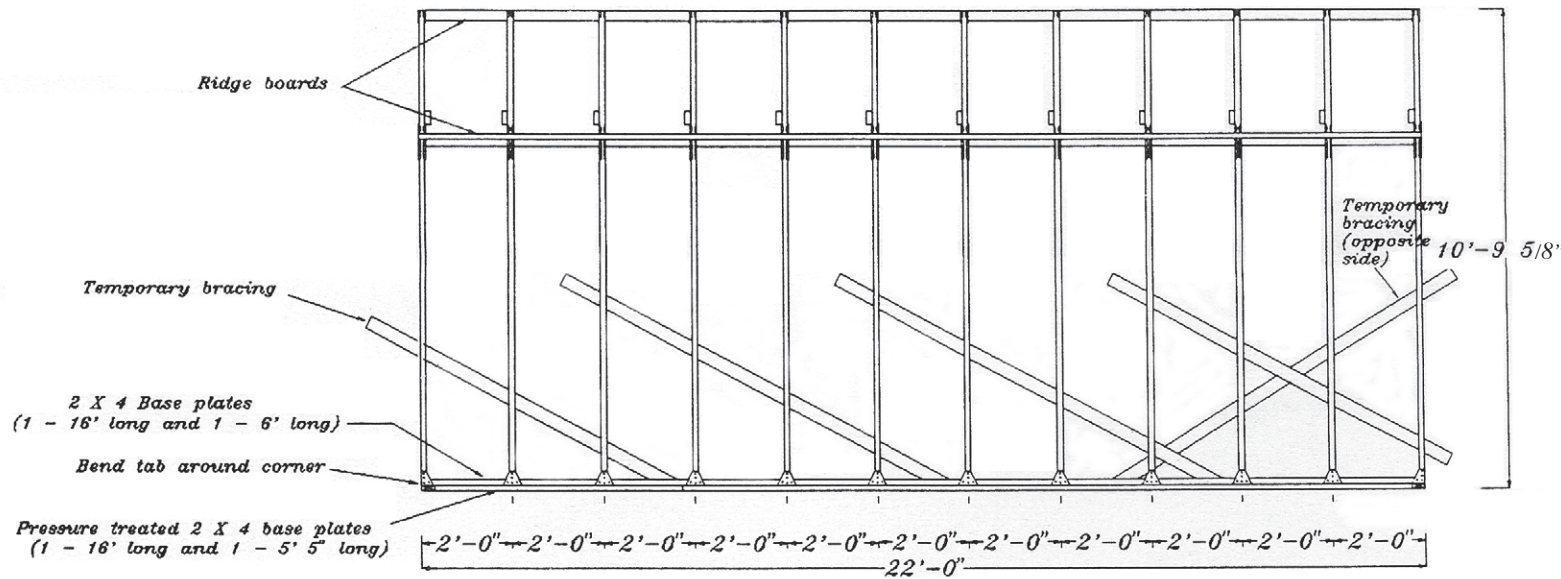

CUT LIST (10'X22' Building)

24 — 2X4 Studs cut to 7' 6-1/4"	(Cut from 24 - 8')
24 — 2X4 Rafters cut to 5' 2-7/8"	(Cut from 12 - 12')
12 — 2X4 Cross ties cut to 7' 6-5/8"	(Cut from 12 - 8')
2 — 2X4 Door jambs cut to 7' 11-1/2"	(Cut from 2 - 8')
2 — 2X4 Vertical studs (back wall) cut to 7' 11 1/2"	(Cut from 2 - 8')
2 — 2X4 Base plates 16' long	(Use 2 - 16')
2 — 2X4 Base plates cut to 6'	(Cut from 1 - 12')
2 — 2X4 Base plates cut to 9' 4"	(Cut from 2 - 10')
1 — 2X4 Door header 8' long	(Use 1 - 8')
3 — 2X4 Ridge boards 16' long	(Use 3 - 16')
3 — 2X4 Ridge boards 6' long	(Cut from 1 - 12' and 1 - 8')
10 — 1X4 Temp. bracing/door stiffener	(Use 10 - 8')
2 — 2X4 Pressure treated base plates 16' long	(Use 2 - 16')
2 — 2X4 Pressure treated base plates cut to 9' 11"	(Cut from 2 - 16')
2 — 2X4 Pressure treated base plates cut to 5' 5"	(Cut from above 16's)

G & T SALES

Fast Framer - Gable Roof

Do-It-Yourself-Framing Hardware Using 2x4's

MADE IN U.S.A.

Tools needed: Hammer, Drill, Saw, 2' Level, Square, Ladder

INSTRUCTIONS

1. Cut and stack all lumber in separate areas.
2. Nail BASE PLATES together overlapping ends as shown in Picture #1 to form base frame. Make sure base frame is square by making diagonal measurements equal.
3. Attach STUD BRACKETS (Picture #2) to base frame using measurements on plans. Measurements are to center of brackets
4. Begin arch assembly by sliding 2 RAFTERS into top ANGLE BRACKET and secure with screws. Attach other 2 ANGLE BRACKETS to RAFTERS and secure with screws. In order to make sure each arch is built the same, stand 2x4 scraps in RIDGE BOARD slots (Picture 3). Stack the arches as you assemble them using the 2x4's as alignment devices.
5. After the ANGLE BRACKETS have been attached to one side of all arches, carefully turn arches over and attach ANGLE BRACKETS to other side while using the alignment devices mentioned in step 4. Then attach left and right STUDS to RAFTERS and secure using screws.
6. Nail CROSS TIE to each RAFTER so that ends are equal distances from top ANGLE BRACKET and flush with top edge of RAFTER. Make sure to put the CROSS TIES toward the inside at each end of the building.
7. When all arches are complete, use two people to carefully lift each arch onto the assembled base frame and secure to STUD BRACKETS with screws. Arches should be perpendicular to base frame (use a square). To hold the arches in a perpendicular position, use 1X4's as temporary bracing as shown in drawing. The end arches should be flush with the base frame. Bend STUD BRACKETS around each corner of base frame and secure with screws.
8. When all arches are in place, slide the RIDGE BOARDS into slots in ANGLE BRACKETS. You may need to tap them into place. Make sure the arches are spaced on the RIDGE BOARDS exactly the same as they are on the base frame in accordance with the plans for your size building. Secure RIDGE BOARDS with screws through holes in bottoms of ANGLE BRACKETS. Do each side first and then install the top RIDGE BOARD.
9. Install DOOR JAMBS as shown in drawings for your building size. Use arch as a guide to mark top of DOOR JAMBS and cut at that angle.
10. Install two VERTICAL STUDS in back wall. Nail top to CROSS TIE and toe nail bottom.
11. On the 7'X8' building, attach a 3'X8' plywood strip on each side of roof peak. On the 8'X14' building, attach a 1'X14' plywood strip on each side of roof peak. On the 10'X22' building, attach a 2'X22' plywood strip on each side of roof peak. This will result in a slight overhang at the eaves.
12. Your building frame is now complete and ready to sheathe in the materials of your choice.

HELPFUL HINTS (All Sizes)

1. Square up base frame by measuring diagonally from corner to corner (must be equal distance).
2. Mark the spacing for the arches on the top boards of the base frame prior to assembly. Also mark the ridge boards with exactly the same spacing.
3. Use pressure treated lumber for the bottom boards of the base frame (prevents rotting).
4. Temporarily brace arches (inside building) perpendicular to base frame using 1X4 boards until sheathing is in place (use a square between base frame and arch). Leave nail heads out slightly so they can be easily pulled.
5. Install wall sheathing horizontally on sides of 7'X8' building. Install wall sheathing vertically on ends of 7'X8' building. Install all wall sheathing vertically on larger size buildings. Install roof sheathing horizontally on all building sizes.
6. Roofing material may be metal, corrugated fiberglass, rolled roofing or shingles.
7. Doors can be cut from plywood sheathing. Outline each half with 1X4 boards to make them rigid. Screw hinges to door jambs. On larger buildings, full sheets of plywood may be used to construct 8' doors.
8. On buildings over 16' long, stagger ridge boards so that seams are overlapping (i.e. start a 16' top board at one end of the building and two 16' boards at the opposite end).
9. Optional 1X4's may be used as corner trim.

U.S. Patent #5,524,397 Canadian Patent #2,227,540

415 Reservoir Road • Whitefish, MT 59937 • 1-406-253-5138 or 1-406-250-7054 • Fax 1-800-880-3178

G & T SALES

Fast Framer - Gable Roof

Do-It-Yourself-Framing Hardware Using 2x4's

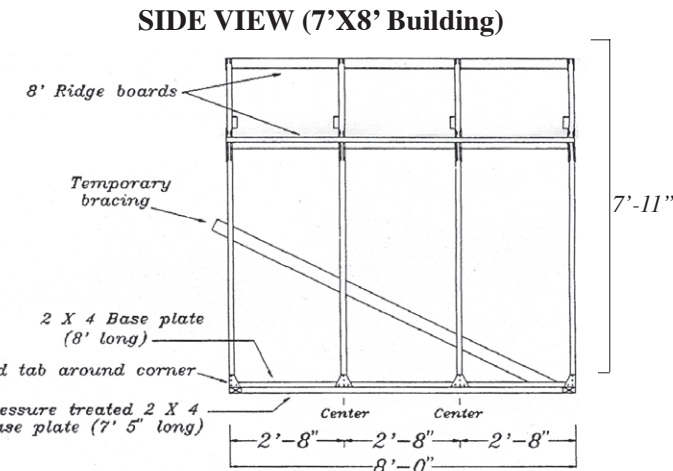
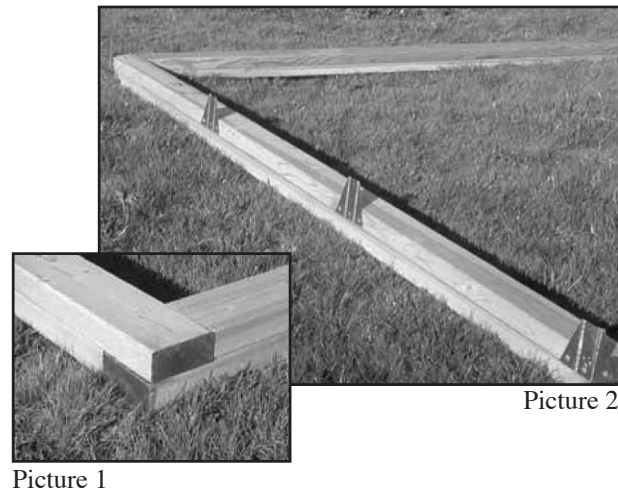
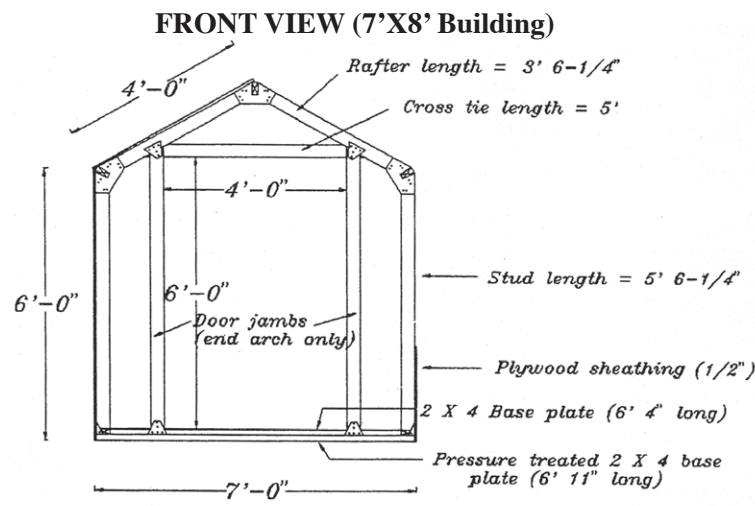

CUT LIST (7' X 8' Building)

- | | |
|---|--------------------|
| 8 - 2X4 Studs cut to 5' 6-1/4" | (Cut from 4 - 12') |
| 8 - 2X4 Rafters cut to 3' 6-1/4" | (Cut from 4 - 8') |
| 4 - 2X4 Cross ties cut to 5' | (Cut from 2 - 10') |
| 2 - 2X4 Door jambs cut to 6' 3-1/2" | (Cut from 2 - 8') |
| 2 - 2X4 Vertical studs (back wall) cut to 6' 3-1/2" | (Cut from 2 - 8') |
| 3 - 2X4 Ridge boards 8' long | (Use 3 - 8') |
| 2 - 2X4 Base plates 8' long | (Use 2 - 8') |
| 2 - 2X4 Base plates cut to 6' 4" | (Cut from 2 - 8') |
| 4 - 1X4 Temp. bracing /door stiffener | (Use 4 - 8') |
| 2 - 2X4 Pressure treated base plates cut to 7' 5" | (Cut from 1 - 16') |
| 2 - 2X4 Pressure treated base plates cut to 6' 11" | (Cut from 1 - 16') |

MATERIALS LIST (7'X8' Building)

- 1 - Fast Framer Kit
- 15 - 8' 2X4's
- 2 - 10' 2X4's
- 4 - 12' 2X4's
- 2 - 16' Pressure Treated 2x4's
- 4 - 8' 1X4's
- 9 - 4X8 Sheets of sheathing material of your choice (plywood, waferwood, T-111 etc.)
- 64 square feet of roofing material of your choice (metal, fiberglass, rolled roofing, shingles, etc.)
- 2# - 3" Nails (16d)
- 2# - 1-1/4" Deck screws

MATERIALS LIST (8'X14' Building)

- 2 - Fast Framer Kits
- 19 - 8' 2X4's
- 12 - 10' 2X4's
- 4 - 12' 2X4's
- 5 - 14' 2X4's
- 3 - 16' Pressure Treated 2x4's
- 6 - 8' 1X4's
- 16 - 4X8 Sheets of sheathing material of your choice (plywood, waferwood, T-111 etc.)
- 150 square feet of roofing material of your choice (metal, fiberglass, rolled roofing, shingles, etc.)
- 2# - 3" Nails (16d)
- 3# - 1-1/4" Deck screws

FRONT VIEW (8'X14' Building)

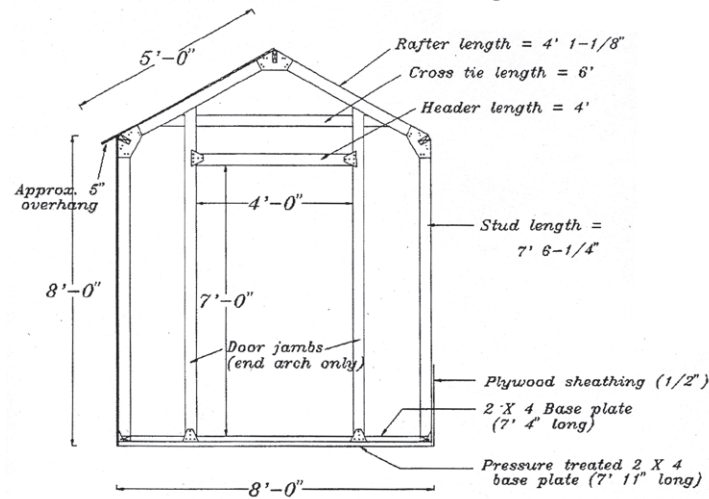

CUT LIST (8' X 14' Building)

- | | |
|---|--------------------|
| 16 - 2X4 Studs cut to 7' 6-1/4" | (Cut from 16 - 8') |
| 16 - 2X4 Rafters cut to 4' 1-1/8" | (Cut from 8 - 10') |
| 8 - 2X4 Cross ties cut to 6' | (Cut from 4 - 12') |
| 2 - 2X4 Door jambs cut to 8' 6-1/4" | (Cut from 2 - 10') |
| 2 - 2X4 Vertical studs (back wall) cut to 8' 6 1/4" | (Cut from 2 - 10') |
| 2 - 2X4 Base plates 14' long | (Use 2 - 14') |
| 2 - 2X4 Base plates cut to 7' 4" | (Cut from 2 - 8') |
| 1 - 2X4 Door header cut to 4' | (Cut from 1 - 8') |
| 3 - 2X4 Ridge boards 14' long | (Use 3 - 14') |
| 6 - 1X4 Temp. bracing/door stiffener | (Use 6 - 8') |
| 2 - 2X4 Pressure treated base plates cut to 13' 5" | (Cut from 2 - 16') |
| 2 - 2X4 Pressure treated base plates cut to 7' 11" | (Cut from 1 - 16') |

MATERIALS LIST (10'X22' Building)

- 3 - Fast Framer Kits
- 42 - 8' 2X4's
- 2 - 10' 2X4's
- 14 - 12' 2X4's
- 5 - 16' 2X4's
- 4 - 16' Pressure Treated 2x4's
- 10 - 8' 1X4's
- 26 - 4X8 Sheets of sheathing material of your choice (plywood, waferwood, T-111 etc.)
- 264 square feet of roofing material of your choice (metal, fiberglass, rolled roofing, shingles, etc.)
- 3# - 3" Nails (16d)
- 5# - 1-1/4" Deck screws

