

# BUMPER POOL TABLE ASSEMBLY INSTRUCTIONS



NG2404PG











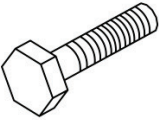

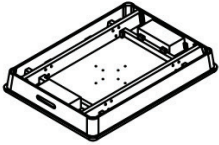
**THANK YOU!**

Thank you for your purchase of our product.

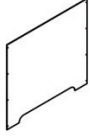
We work around the clock and around the globe to ensure that our products maintain the highest possible quality. However, in the rare instance that your product is defective or missing parts, contact Challenger Manufacturing at 800-759-0977 to submit parts requests or warranty claims. Please read the warranty information at the back of these assembly instructions for further details.

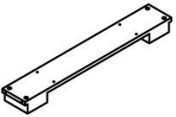
**IMPORTANT! PLEASE READ THESE ASSEMBLY INSTRUCTIONS IN ENTIRETY BEFORE ASSEMBLING YOUR PRODUCT.**

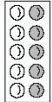
# PARTS IDENTIFIER (NOT TO SCALE)

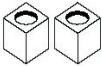
<p>#1</p>  <p><b>LEG LEVELER</b> 4 pcs</p>	<p>#2</p>  <p><b>BOLT</b> 12 pcs</p>	<p>#3</p>  <p><b>FLAT WASHER</b> 24 pcs</p>	<p>#4</p>  <p><b>NUT</b> 12 pcs</p>	<p>#5</p>  <p><b>TABLE BODY</b> 1 pc</p>
<p>#6</p>  <p><b>WRENCH</b> 1 pc</p>	<p>#7</p>  <p><b>3/4" SCREW</b> 56 pcs</p>	<p>#8</p>  <p><b>1-3/4" SCREW</b> 16 pcs</p>	<p>#9</p>  <p><b>LEG PANEL</b> 4 pcs</p>	<p>#10</p>  <p><b>LEG SIDE</b> 4 pcs</p>
<p>#11</p>  <p><b>LEG BASE</b> 2 pcs</p>	<p>#12</p>  <p><b>LEG TOP</b> 2 pcs</p>	<p>#13</p>  <p><b>BUMPER POOL BALLS</b> 1 SET</p>	<p>#14</p>  <p><b>BUMPER POOL CUE STICK</b> 2 pcs</p>	<p>#15</p>  <p><b>BRUSH</b> 1 pc</p>
<p>#16</p>  <p><b>CHALK</b> 2 pcs</p>				

ADDITIONAL EQUIPMENT REQUIRED:



Please see Parts List at end of manual for part number when ordering parts. For replacement parts please call 800-759-0977.

## ASSEMBLY TIPS

1. Find a clean, level surface to begin the assembly of your game table. The table will be partially assembled upside down and then turned over onto its legs. This is a heavy game and turning it over will require at least two strong adults.
2. Remove all of the contents from box and verify that you have all of the parts shown on the Parts Identifier before you begin assembly. **Note: Some parts may be pre-installed or pre-assembled.**
3. Some figures or drawings may not look exactly like your product. Please read and understand the text before beginning each assembly step.
4. **When installing parts that have more than one screw or bolt, hand tighten all screws or bolts in place before finishing tightening with screwdriver or hex wrench.**
5. Electric screwdrivers may be helpful during assembly; however, please set a low torque and use extreme caution because screws may be stripped or overtightened if the electric screwdriver's torque is set too high.

### **WARNINGS!**

READ AND FOLLOW ALL ASSEMBLY, OPERATION AND SAFETY INSTRUCTIONS CAREFULLY.

CHOKER HAZARD - THIS TABLE CONTAINS SMALL BALLS AND PARTS - NOT  
SUITABLE FOR CHILDREN UNDER 3 YEARS OF AGE.

# ASSEMBLY INSTRUCTIONS

1. Begin LEG assembly by attaching LEG BASE #11 and LEG TOP #12 to one LEG SIDE #10 with 1-3/4" SCREW #8. Attach one LEG PANEL #9 with 3/4" SCREW #7. Attach remaining LEG SIDE #10 with 1-3/4" SCREW #8. Attach remaining LEG PANEL #9 with 3/4" SCREW #7. Repeat assembly for remaining LEG.

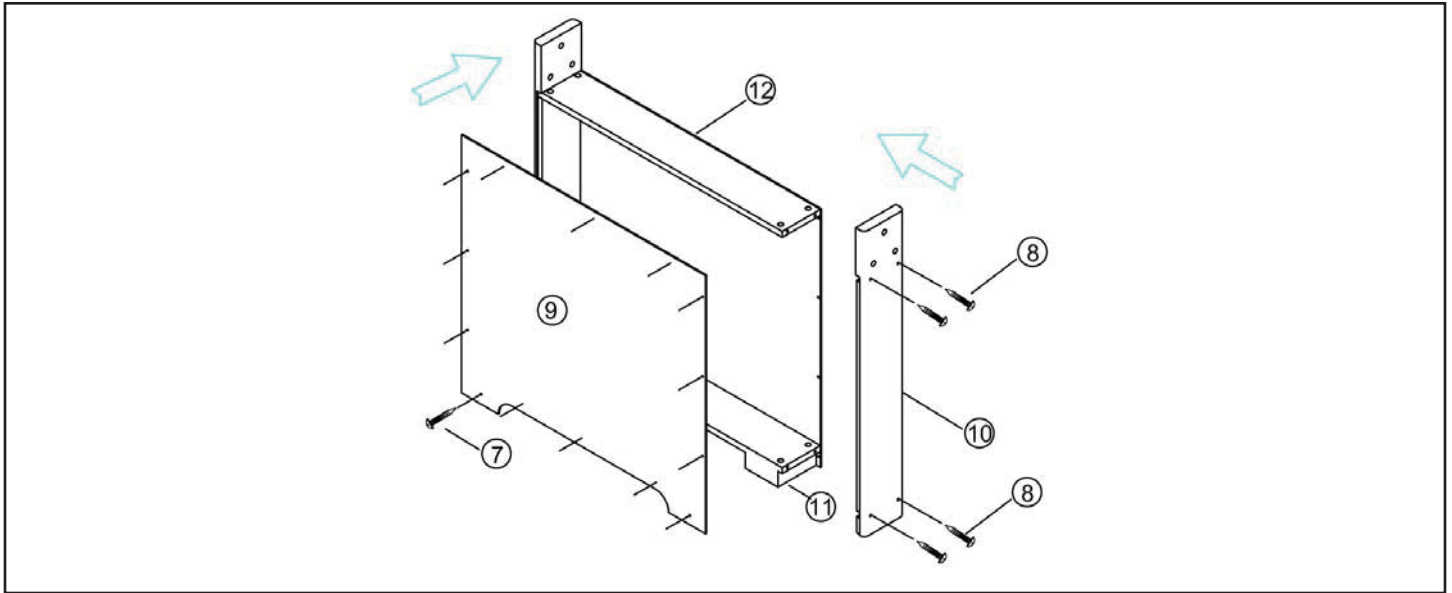

2. Attach each assembled LEG to the bottom of the TABLE BODY #5 with BOLT #2, NUT #4 and FLAT WASHER #3.

3. Thread two LEG LEVELERS #1 into the bottom of each LEG.

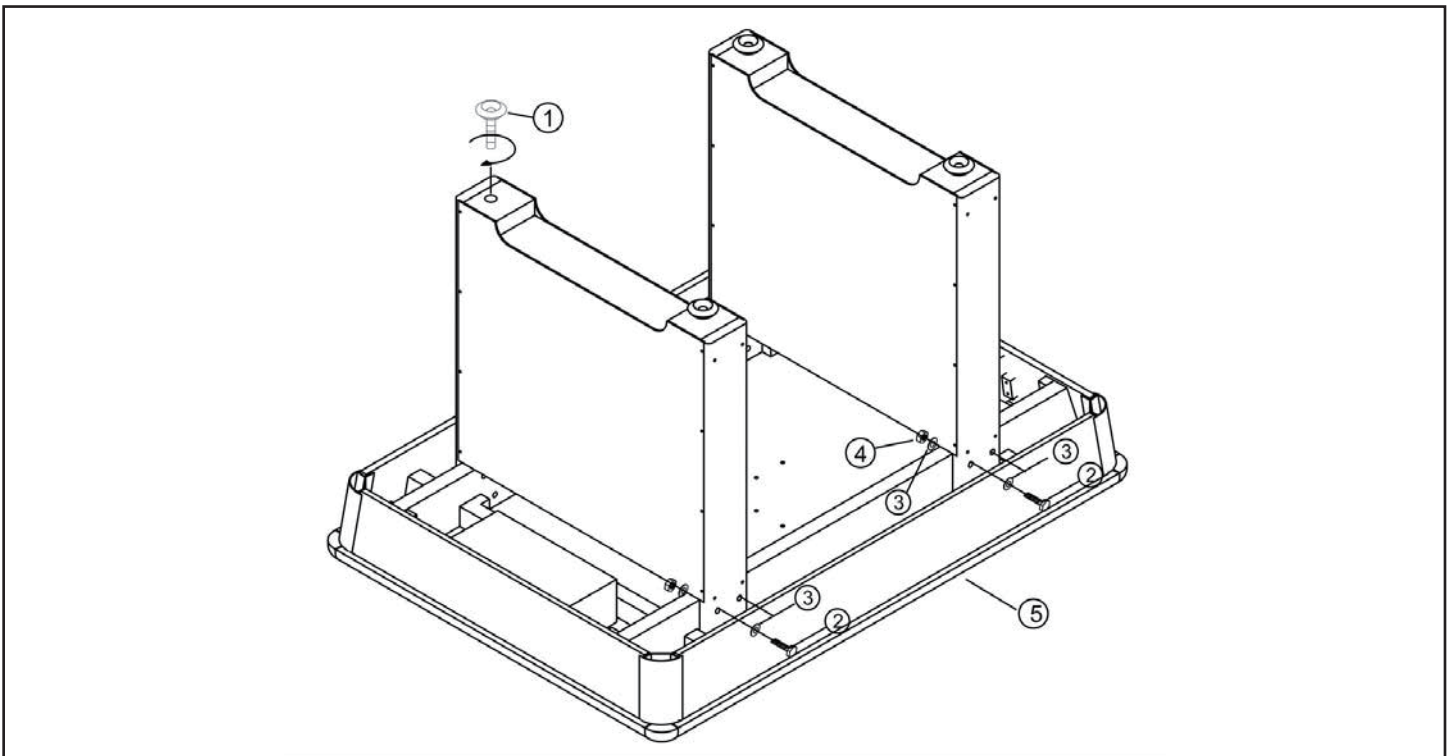

**CONGRATULATIONS!**

You have now assembled your Game Table. Please note the Care and Use instructions below to ensure years of trouble free use of your game table.

### **CARE AND USE**

1. This product is intended for INDOOR use only.
2. Do NOT sit, climb or lean on the table.
3. Do NOT drag the table when moving it as this will damage the legs.

## 90-DAY LIMITED WARRANTY

This Challenger Manufacturing product is warranted to the original purchaser to be free from defects in material or workmanship for a period of ninety days from the date of the original retail purchase.

This warranty does not cover defects or damage due to improper installation, alteration, accident or any other event beyond the control of the manufacturer. Defects or damage resulting from misuse, abuse or negligence will void this warranty. This warranty does not cover scratching or damage that may result from normal usage.

This product is not intended for institutional or commercial use; Challenger Manufacturing does not assume any liability for such use. Institutional or commercial use will void this warranty.

This warranty is nontransferable and is expressly limited to the repair or replacement of the defective product. During the warranty period, Challenger Manufacturing shall repair or replace defective parts at no cost to the purchaser. Shipping charges and insurance are not covered and are the responsibility of the purchaser. Labor charges and related expenses for removal, installation or replacement of the product or components are not covered under this warranty.

Challenger Manufacturing reserves the right to make substitutions to warranty claims if parts or unavailable or obsolete.

Challenger Manufacturing shall not be liable for loss of use of the product or other consequential or incidental costs, expenses or damages incurred by the consumer of any other use. The user assumes all risk of injury resulting from the use of this product.

This warranty is expressly in lieu of all other warranties, expressed or implied, including warranties of merchantability or fitness for use to the extent permitted by Federal or state law. Neither Challenger Manufacturing nor any of its representatives assumes any other liability in connection with this product.

**All warranty claims must be made through the retailer where the product was originally purchased. A purchase receipt or other proof of date of purchase will be required to process all warranty claims. The model number and part numbers found within the assembly instructions will be required when submitting any parts requests or warranty claims.**

**For further warranty information or inquiries, please call 800-759-0977**

# PARTS LIST

## NG2400PG

NAME:

Product	Description	Parts Identifier Numebr
NGP5693	TABLE BODY	5
NGP5694	LEG PANEL	9
NGP5695	LEG SIDE	10
NGP5696	LEG BASE	11
NGP5697	LEG TOP	12
NGP5698	BUMPER POOL BALLS	13
NGP5699	BUMPER POOL CUE STICK	14
NGP5073	BRUSH	15
NGP5077	CHALK	16
NGP5700	HARDWARE PACK	1,2,3,4,6,7,8

## NG2404PG

NAME:

Product	Description	Parts Identifier Numebr
NGP5705	TABLE BODY	5
NGP5706	LEG PANEL	9
NGP5707	LEG SIDE	10
NGP5708	LEG BASE	11
NGP5709	LEG TOP	12
NGP5698	BUMPER POOL BALLS	13
NGP5699	BUMPER POOL CUE STICK	14
NGP5073	BRUSH	15
NGP5077	CHALK	16
NGP5711	HARDWARE PACK	1,2,3,4,6,7,8

For replacement parts please call 800-759-0977